

SRX SERIES

Module type
High-speed Digital Controller

SRX



CE   
CE,UL,CSA pending

RKC RKC INSTRUMENT INC.

Ultra High Speed Temperature Control

Sampling

0.025 sec

High-Speed Response >>>

High-speed feedback control of 40 samples per second

SRX is a digital controller with a super high speed sampling of control updating cycle time of 25ms (0.025 sec). Supplied with high resolution input and parameters settable in 1/100 sec. for process applications with fast response. Applications in RTP (Rapid Thermal Process) in semiconductor manufacturing process that were difficult to handle with conventional controllers such as pulse heat temperature control of flip chip bonders, lamp annealing with halogen lamps can be solved. Other applications include pressure, flow rate and other process control applications.

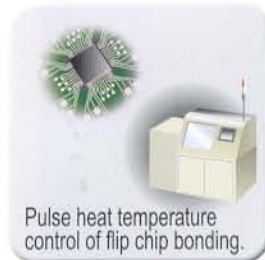
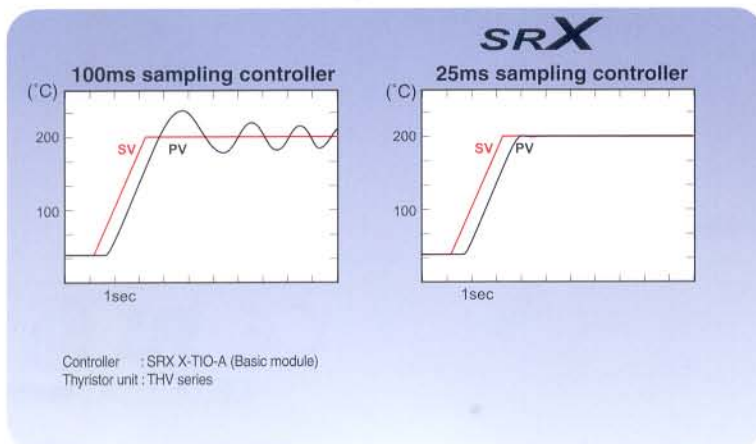

Specifications

Input

Number of inputs	2 points (isolated between each channel) • 2nd input can be used as a remote input
Input	a) Thermocouple • Low voltage group Thermocouple : K, J, E, T, R, S, B, N (JIS/IEC) PLII (NBS), W5Re/W26Re (ASTM) Low voltage : 0 to 1V DC, 0 to 100mV DC, 0 to 10mV DC b) RTD group Pt100 (JIS/IEC), JPt100 (JIS) • 3-wire system c) High voltage • Current group High voltage : 0 to 5V DC, 1 to 5V DC, 0 to 10V DC Current : 4 to 20mA DC, 0 to 20mA DC (Input impedance : 250Ω) • Inputs are freely selectable within each group.
Sampling time	0.025 sec.
Influence of external resistance	0.25μV/Ω (Thermocouple input)
Influence of lead resistance	Maximum 10Ω per wire (RTD input)
Input break action	Thermocouple input : Up-scale RTD input : Up-scale 0 to 10mV DC, 0 to 100mV DC : Up-scale 0 to 1V DC, 0 to 5V DC, 1 to 5V DC, 0 to 10V DC : Value around 0V Current input : Value around 0mA
Input short action	Down-scale (RTD input)
Input digital filter	0.01 to 10.00 sec. (OFF when 0 is set.)
PV bias	-span to +span

Performance

Measuring accuracy	See input code table
Insulation resistance	More than 500V DC 20MΩ between each isolation block
Dielectric voltage	More than 600V AC 1 minute between each isolation block

Control

Control method	Brilliant PID control (with autotuning) • Direct action/Reverse action selectable
Setting range	a) Proportional band : Temperature input, 0 to input span(°C, °F) Voltage • Current input, 0.0 to 1000.0% of input span b) Integral time : 0.01 to 360.00 sec or 0.1 to 3600.0 sec (selectable) c) Derivative time : 0.00 to 360.00 sec or 0.0 to 3600.0 sec (selectable) d) Control response : Slow, Medium, Fast e) Output limiter : -5.0 to +105.0% (High/Low individual setting) f) Output change rate limiter : 0.0 to 100.0%/sec g) Proportional cycle : 0.2 to 50.0 sec h) Level PID : 8 sets of PID parameters can be assigned to set values at different points.
Output	a) Relay contact output, Form a contact, 250V AC 3A (resistive load) • Electric life : 300,000 cycles or more (resistive load) b) Voltage pulse output DC 0/12V (Load resistance : more than 600Ω) c) Current output 4 to 20mA DC, 0 to 20mA DC (Load resistance : less than 600Ω) d) Continuous voltage output 0 to 5V DC, 1 to 5V DC, 0 to 10V DC (Load resistance : more than 1kΩ)

Event (Alarm) output

Number of alarm	Up to 2 points/ch
Alarm types	Deviation high, Deviation low, Deviation high/low, Band, Process high, Process low * Hold action is available except for Band.
Setting range	a) Deviation alarm : -span to +span b) Deviation high/low, Band : 0 to span c) Process alarm : Same as input range
Differential gap	Temperature input : 0 to 10°C(°F) or 0.0 to 10.0°C(°F) Voltage • current input : 0 to 100digit
Output	Communication data output

Control loop break alarm : LBA

Number of alarm	2 points
LBA time setting	0 to 7200 sec. (LBA is OFF when 0 is set)
LBD deadband setting	0 to input span
Output	Communication data output

Heater break alarm : HBA (Optional)

Number of alarm	2 points
CT type	CTL-6-P-N, CTL-12-S56-10L-N (Specify when ordering)
Input range	CTL-6-P-N : 0 to 30A CTL-12-S56-10L-N : 0 to 100A
Display range	0.0 to 100.0A
Display accuracy	±5% of input value or ±2A (whichever is larger)
Output	Communication data output

Program control

Storage Program pattern	Max.16 patterns (Max.16 segment per pattern) • With pattern link function
Storage segments	Max.256 segments (16 patterns x 16 segments)
Program setting	Level setting (Setting per channel) Segment time (Setting per channel)
Setting range	Level : Same as input range Segment time : 0.00 to 300.00 sec. / 0.0 to 3000.0 sec. / 0 to 30000 sec. / 0 to 30000 min (selectable)
Program repeat	1 to 1000 times (Continuous when 1000 times is set)
Time accuracy	± (0.01% of reading + 1 digit)
Start mode	Zero start, Fixed time type PV start, Time shorting/ Constant slope type PV start (selectable)
Functions	HOLD function / STEP function / WAIT function
Control mode	Reset mode / Program control mode/ Fixed control mode / Manual control mode
Time signal	16 points per 1 pattern • Contact outputs of time signals are provided from a DO module (available soon).

Communications

Communication method	Based on RS-485 (2-wire, half duplex connection)
Protocol	a) ANSI X3.28 (1976) 2.5 A4 b) MODBUS • Selectable
Communication speed	2400, 9600S, 19200, 38400BPS (selectable)
Bit configuration	Start bit : 1, Data bit : 7 or 8 Parity bit : Without, Odd or even Stop bit : 1
Maximum connection	31 units

General Specifications

Supply voltage	21.6 to 26.4V DC [Including supply voltage variation] (Rating 24V DC)
Power consumption	Basic module : Maximum 120mA Extension module : Maximum 120mA
Power failure	A power failure of 20msec or less will not affect the control action. If power failure of more than 20msec occurs, controller will restart. HOT or COLD start is selectable.
Memory backup	Backed up by non-volatile memory (FRAM). (Data retaining period : Approx.10 years, Number of writing : Approx.10,000,000,000 times, • Depending on storage and operating conditions.
Ambient temperature	-10 to 50°C (14 to 122°F)
Ambient humidity	20 to 85%RH (No dew condensation)
Weight	Basic module : 220g Extension module : 190g
External dimensions	See external dimensions
Operating environment	Free from corrosive and flammable gas and dust.
Other conditions	Free from external noise, vibration, shock and exposure to direct sunlight.

Compliance with Standards

CE Mark, UL Recognized, CSA Certified, C-Tick mark (Pending)

External Dimensions

(Unit:mm)

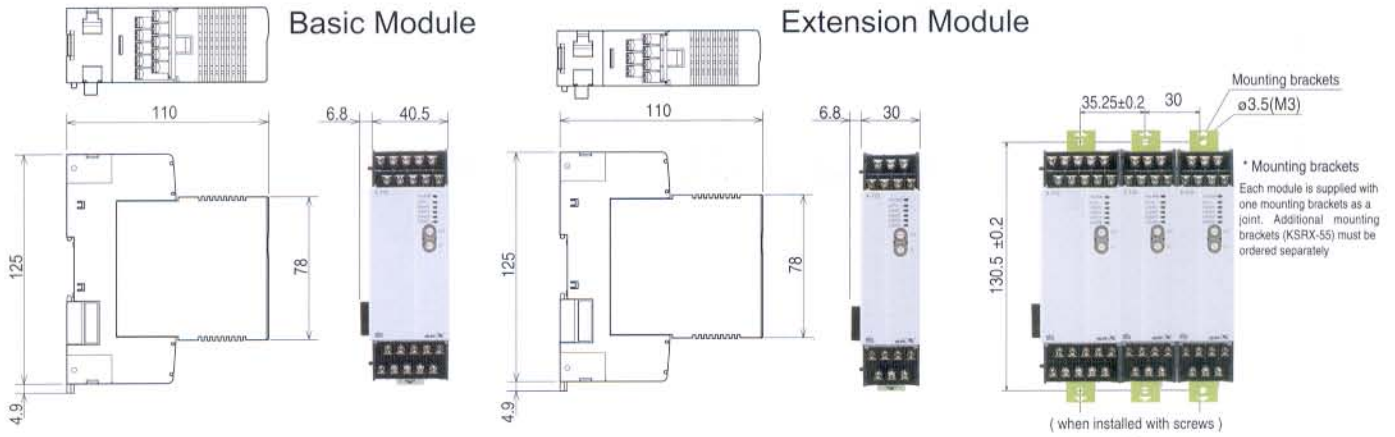

Terminals



Basic Module

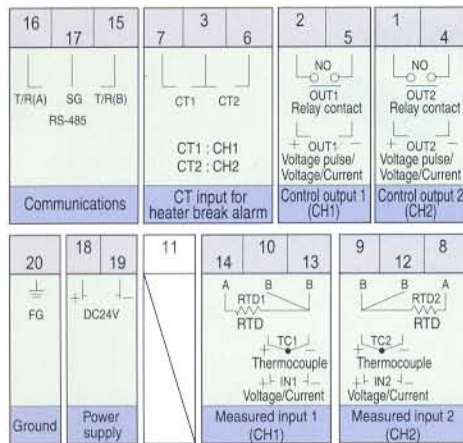

* 2nd input can be used as a remote setpoint. (voltage/current input only)
In this setup, control output 2 and CT input 2 are not available.



Extension Module

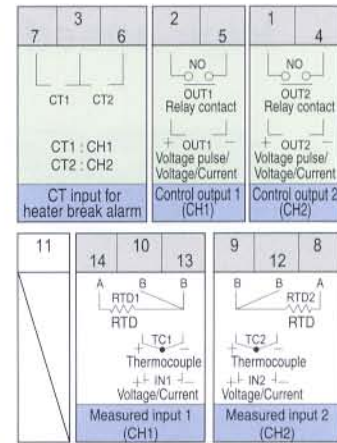

* 2nd input can be used as a remote setpoint. (voltage/current input only)
In this setup, control output 2 and CT input 2 are not available.

System Configuration

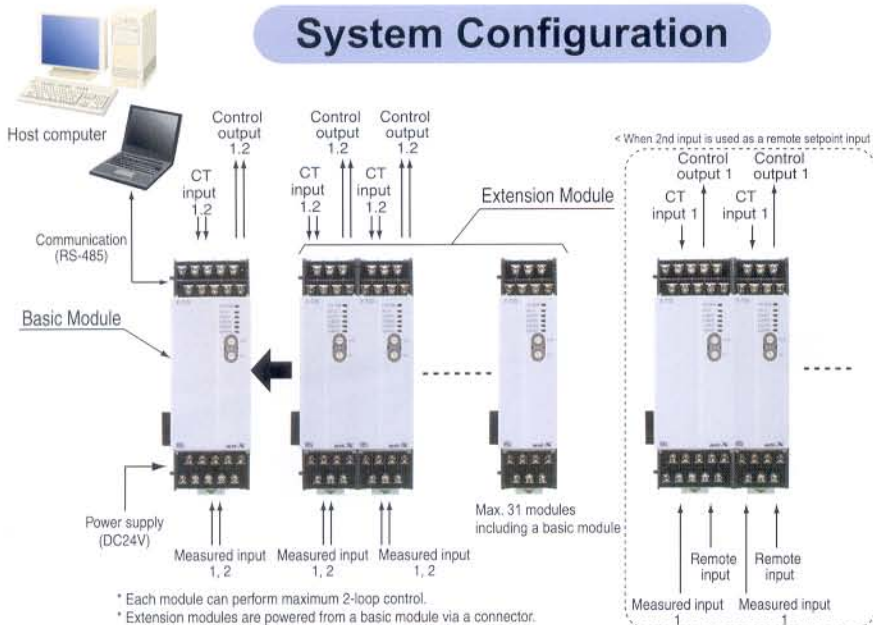

- * Each module can perform maximum 2-loop control.
- * Extension modules are powered from a basic module via a connector.
- * Communication of extension modules is via a connector.
- * Input and output types can be freely specified for each module and channel.
- * Time signal outputs (in program control mode) are provided from a DO module (available soon)

Name of Parts

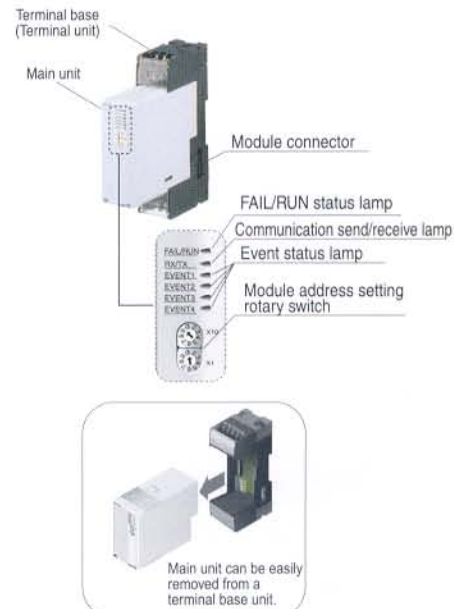

The Ultimate In Sampling Speed



Module type
High-speed Digital Controller

SRX

Multi-zone space-saving

Dual loop control can be performed with a single compact module. A maximum of 31 modules can be connected for 62-loop control. Power supply and communication lines are via a connector on the side, no wiring required. Distributed installation via RS-485 is possible, enabling multi-zone distributed control system in a compact size.

Dual loop control with a single module

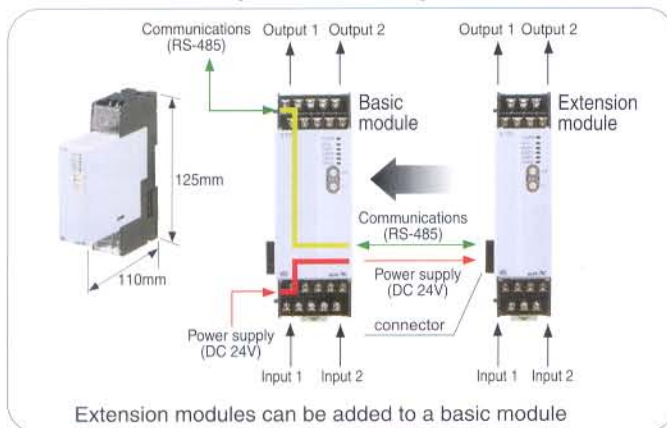

Up to 31 modules can be connected

Connection of extension modules to a basic module

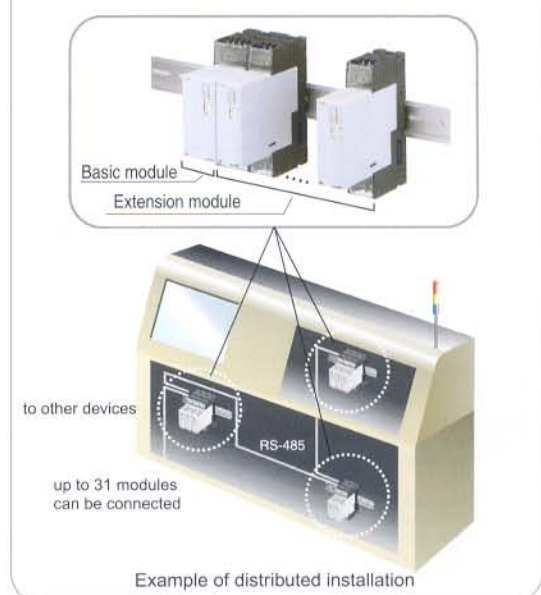

Ramp/Soak program function

Ramp/Soak program control of 16 segments by 16 patterns is supplied as standard. Control can be selected from a standard fixed-setpoint control and ramp/soak program control.

Model and Suffix Code

X-TIO

Specifications	Suffix Code					
	High-speed digital controller (Module type) X-TIO - □ - □ □ □ □ □ □ □ □					
Type	Basic module	A				
	Extension module	B				
Measured input 1 (CH1)	See input code table		□			
Measured input 2 (CH2)	See input code table			□		
Control output 1 (CH1)	Relay contact output				M	
	Voltage pulse output 0/12V DC				V	
	Continuous voltage output 0 to 5V DC				4	
	Continuous voltage output 0 to 10V DC				5	
	Continuous voltage output 1 to 5V DC				6	
	Current output 0 to 20mA				7	
	Current output 4 to 20mA				8	
Control output 2 (CH2)	Relay contact output				M	
	Voltage pulse output 0/12V DC				V	
	Continuous voltage output 0 to 5V DC				4	
	Continuous voltage output 0 to 10V DC				5	
	Continuous voltage output 1 to 5V DC				6	
	Current output 0 to 20mA				7	
	Current output 4 to 20mA				8	
CT input 1 (CH1)	No CT input					N
	CTL-6-P-N					P
	CTL-12-S56-10L-N					S
CT input 2 (CH2)	No CT input					N
	CTL-6-P-N					P
	CTL-12-S56-10L-N					S

* Extension module alone cannot be used.

* The second PV input can be also used as a remote setpoint input (voltage/current input only).

* When a heater break alarm (HBA) is used, please specify relay output or voltage pulse output for the relevant channel output.

Accessory

Name	Model code
Current transformer for heater break alarm	CTL-6-P-N (0 to 30A) CTL-12-S56-10L-N (0 to 100A)

Input Code Table

Input type	Range	Code	Measuring accuracy	Resolution			
Thermocouple, Low voltage group	K	-200 to 1372°C, -328 to 2501°F	K	Less than 100°C (-148°F): ±1.0°C (±1.8°F) -100 to 500°C (-148 to 932°F): ±0.5°C (±0.9°F) More than 500°C (932°F): ±(0.1% of Reading+1digit)	*1 1°C, 0.1°C 1°F, 0.1°F (Selectable)		
	J	-200 to 1200°C, -328 to 2192°F	J				
	T	-200 to 400°C, -328 to 752°F	T				
	E	-200 to 1000°C, -328 to 1832°F	E				
	PLII	0 to 1390°C, 32 to 2534°F	A				
	N	0 to 1300°C, 32 to 2372°F	N				
	S	-50 to 1768°C, -58 to 3000°F	S			-50 to 1000°C (-58 to 1832°F): ±1.0°C (±1.8°F) More than 1000°C (1832°F): ±(0.1% of Reading+1digit)	
	R	-50 to 1768°C, -58 to 3000°F	R				
	W5Re/W26Re	0 to 2300°C, 32 to 3000°F	W			Less than 400°C (752°F): ±70.0°C (±126°F) 400 to 1000°C (752 to 1832°F): ±1.0°C (±1.8°F) More than 1000°C (1832°F): ±(0.1% of Reading+1digit)	*1 1, 0.1, 0.01, 0.001, 0.0001 (Programmable)
	B	0 to 1800°C, 32 to 3000°F	B				
0 to 10mV DC 0 to 100mV DC 0 to 1V DC	-20000 to 20000 (Programmable within 20,000 span)	1 2 3	±(0.1% of Span)	1, 0.1, 0.01, 0.001, 0.0001 (Programmable)			
	RTD group	PI100			-200 to 850°C, -328 to 1562°F	Less than 200°C (±392°F): ±0.2°C (±0.4°F) More than 200°C (±392°F): ±(0.1% of Reading+1digit)	1°C, 0.1°C, 1°F, 0.1°F (Selectable)
		JP1100			-200 to 600°C, -328 to 1112°F	P	
High voltage, Current group	0 to 5V DC	-20000 to 20000 (Programmable within 20,000 span)	4	±(0.1% of Span)	1, 0.1, 0.01, 0.001, 0.0001 (Programmable)		
	0 to 10V DC		5				
	1 to 5V DC		6				
	0 to 20mA DC		7				
	4 to 20mA DC		8				

*1 Cold junction temperature compensation error: ±1.0°C (±1.8°F) [at 23°C (±2°C) (73.4°F ±3.6°F)],
 Within ±1.5°C (±2.7°F) [Between 0 and 50°C (14 to 122°F)]

New!

Thyristor unit THV series

Digital control for high speed response and high resolution.
 Compact size of 48mm width.
 Various programming such as ramp setting via front keys and 7-segment LEDs.

Control output

Sensor input

Applications example

Controlled object



• Before operating this product, read the instruction manual carefully to avoid incorrect operation.
 • This product is intended for use with industrial machines, test and measuring equipment. It is not designed for use with medical equipment.
 • If it is possible that an accident may occur as a result of the failure of the product or some other abnormality, an appropriate independent protection device must be installed.
 • When installing this product, avoid the following:
 • Direct exposure to sunlight.

• An ambient temperature lower than 0°C or higher than 50°C
 • Areas subject to high humidity. Ambient humidity should not be lower than 45% or higher than 85%RH
 • Direct contact with water.
 • Corrosive environments.
 • Hazardous areas containing explosive or flammable gases.
 • Vibration or shock.
 • Areas subject to electrical noise caused by inductive interference, static electricity or magnetic fields.

RKC RKC INSTRUMENT INC.
 (RIKA KOGYO CO., LTD)

HEAD OFFICE : 16-6, KUGAHARA 5 CHOME OHTA-KU TOKYO 146-8515 JAPAN
 PHONE : 03-3751-9799 (+81 3 3751 9799)
 Email : info@rkcinst.co.jp
 FAX : 03-3751-8585 (+81 3 3751 8585)
 http://www.rkcinst.com/